

UNIVERSITY OF ZIELONA GÓRA
FACULTY OF MECHANICAL ENGINEERING

in association with the  Design Society

THIRD INTERNATIONAL
SEMINAR AND WORKSHOP

10th - 12th October 2002
Zielona Góra - Łagów
POLAND

ENGINEERING DESIGN IN INTEGRATED PRODUCT DEVELOPMENT

Design Methods that Work

DESIGNING PARALLEL KINEMATICS MODULAR MACHINE TOOLS – NEW APPROACH

A. Owczarek, T. Koch

Wroc³aw University of Technology
Institute of Production Engineering and Automation
e-mail: ola@itma.pwr.wroc.pl

Keywords: modularity, design, parallel kinematics

Abstract: Methodics that supports the design process of modular machine tools with parallel kinematics has been described in this paper. Methods belonging to the methodics were described and application aspects were discussed

1. INTRODUCTION

1.1. Modularity

The goal of implementing modularity into production is mainly to rationalize production and product design and to limit the number of product variants. The most important advantages of modularity are: decrease in order processing time, possibility of product range expansion, cost reduction due to economics of scale, improved product quality, easier maintenance, control and ability to expand or update the product.

Therefore designers need to use simple methods to create products as modular constructions. A variety of methods are described in many papers [1],[2],[3]. Most of them do not cover the whole design process,

some require advanced calculation techniques. Most of the methods are dedicated for existing products. So there is a need to design a new methodics for modular products design with special attention paid to customer's expectations.

1.2. Parallel kinematics machine tools

Parallel kinematics machine tools are a very interesting segment of the machine tool industry. They can be very good objects of modularity thanks to their construction. Smart modularity process of a specific machine can reduce its cost which is in most cases very high. Fig. 1 shows an example of parallel kinematics machine tool which was designed in Centre for Advanced Manufacturing Technology (CAMT) in Wroclaw University of Technology.

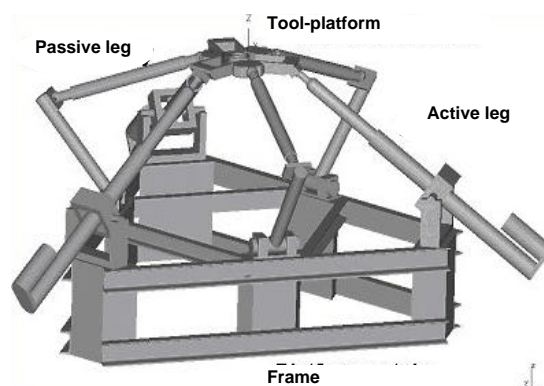

Fig. 1. Parallel kinematics machine

The advantages of such solution are among others:

- high stiffness,
- 3-6 degrees of freedom,
- small moved weights,
- ability to achieve high speeds and accelerations and as a result decreasing the cycle time,
- HSC, HSM processing,

- five-axis machining,
- machine can be assembled from standard, elements.

These machine tools can be applied for machining of 3D-surfaces, laser or water cutting [4].

2. METHODICS DESCRIPTION

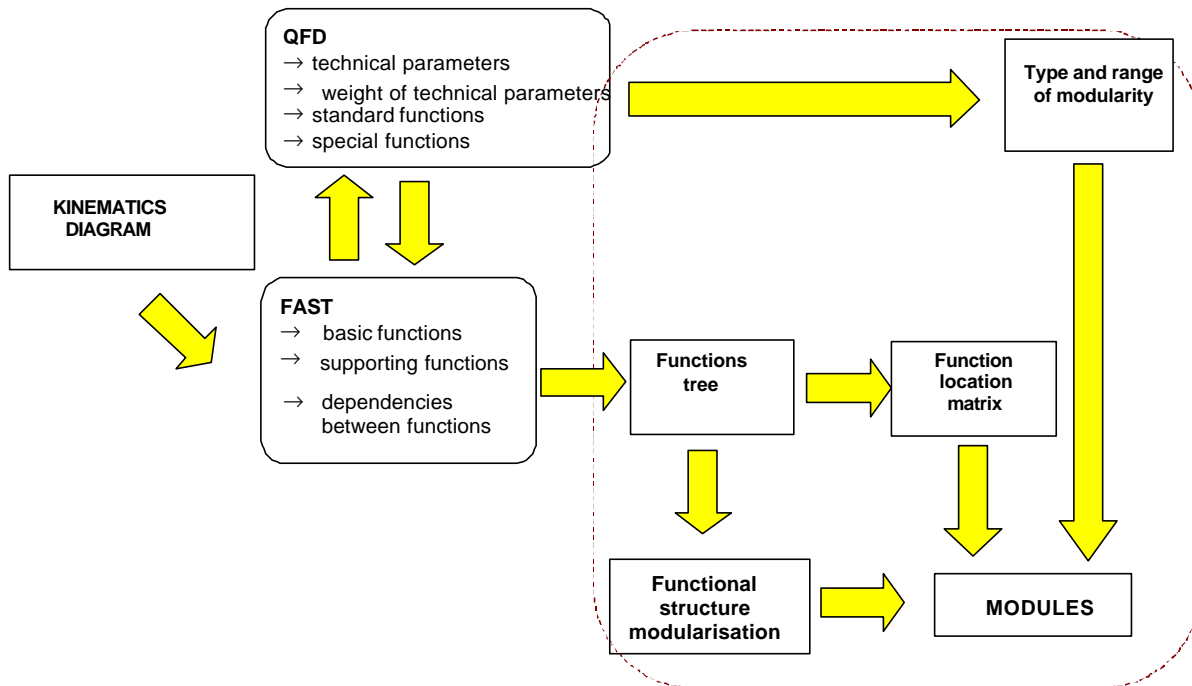

Fig. 2. Modular structure creation diagram

2.1. Working out the modular structure

Fig 2 shows a general diagram of the methodics. The initial concept is a parallel kinematics machine. The concept has been designed earlier – methodics does not include the stage of defining the kinematics of the machine. Two separate approaches to modular products design have been applied here: modularisation of existing products and design for modularity, where the design takes into account future modules. The advantage of this solution is the fact that people looking for new product ideas do not have to take into account additional conditions. On the other hand modularity is implemented early enough to assure that the product is going to be properly divided into modules. This allows to reduce costs and to design modules at the same time. Then, according to the diagram, a QFD analysis is carried out and, parallelly, the analysis of the functional structure of the machine. QFD analysis determines customer's expectations concerning required functions, enhancement or upgrade possibilities. The application of the QFD method also allows to

determine a set of strategic technical parameters and their importance. In the machine's functional structure analysis, which is carried out using FAST (Functional Analysis System Technique) method, main and supporting features and the references between functions are determined, what in later stages allows to group the functions into functional modules. QFD and FAST methods should exchange information during the design of a modular machine. Functional structure should be updated with functions that are important from the customer's point of view, not important or unnecessary functions should be removed from the structure. Information on functional structure and functions that the machine needs to support in order to do its job should be passed from FAST to QFD method. Thank to that the customer can influence the design process and play an important role in the overall product development process. Carrying out both analyses allows to fully determine the required type and scope of modularity (customer's or manufacturer's modularity; fully modular or mixed structure) and functional structure described by the

functions tree. The functional structure described this way is subject to further modularisation which groups individual functions in functional modules. This process can be based on intuition or on results of algorithmic methods described for example in [1],[2]. The functional structure determined this way should be verified against the possibility of creating such modules with regards to the kinematics structure of the machine. Function location matrix is used here. In this matrix fields that correspond to possible locations of the selected functions in the real structure are marked. In case a function can be assigned to more than one element it should be marked. Marked fields in one row suggest that these functions can be grouped together in a module. Simplified example of the location matrix is shown in Table 1.

Table 1. Example of function location matrix

	function 1	function 2	function 3	function N
frame				
active leg 1	X			X
active leg 2	X			X
active leg 3	X			X
passive leg 1		X	X	
passive leg 2		X	X	
passive leg 3		X	X	
tool-platform			X	X

The final stage of determining the modular structure is the assessment, whether it complies with the technical and customer's requirements from the QFD process.

2.2. Machine configuration to order

Modules designed using the described methodics are a base of a catalogue – module database for selected parallel kinematics machine solution. Proper processing of a customer order is shown on Fig. 3.

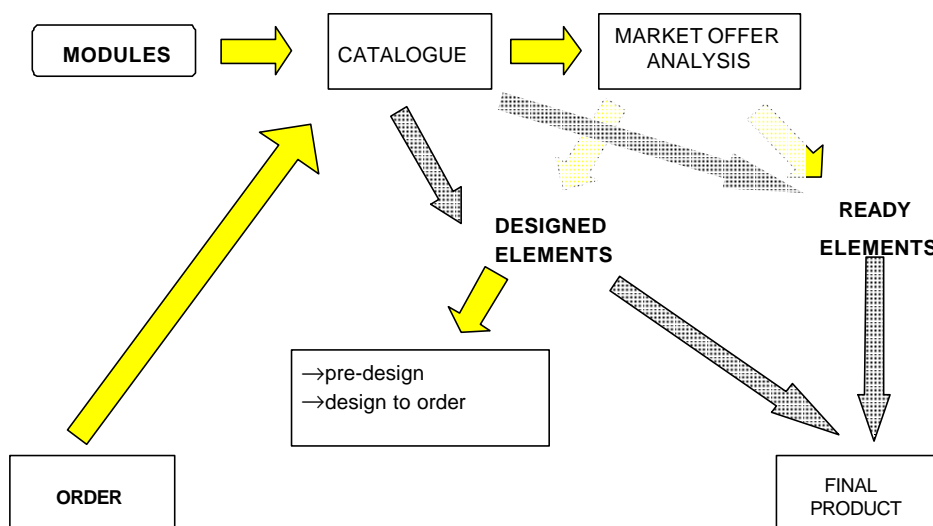

Fig. 3. Processing of a customer order using the modular structure

After the modules necessary to configure the machine have been grouped in a catalogue, market offer should be examined in order to identify the modules that can be purchased. The remaining modules should be designed; some of them can be designed in early stages, some of them have to be designed to a specific customer order as they are going to satisfy the needs of a specific customer group. Therefore when a customer order is received the machine is configured from ready modules delivered by the suppliers, modules designed and manufactured earlier and modules designed especially for the order.

3. DISCUSSION

The methodics of the design of modular machine tools with parallel kinematics which is briefly described in this paper is a different proposal from construction modularity methods developed earlier [1],[2],[3]. Because of the kind of tools that are used it can easily be adopted to specific situations and does not require advanced software support. The described configuration schematics allows both to process a customer order quickly what is characteristic for modular products and to design some elements according to customer's expectations what is characteristic for traditional products. Carrying out the FAST process and developing the function location matrix for parallel kinematics

machine tool adjusts this methodics to the modularisation process of such machine. Dependencies between the tools included in the methodics, their mutual influence and the way of processing the results are very important and have to be stressed here. It allows to fully utilise the possibilities of these tools.

Methodics does not contain any tools to assess existing solutions with regard to their technical-technological aspects as it was described for example in [3]. The only criteria used to group functions in modules are the customer's expectations, dependencies between functions and their location in physical structure of the machine. This approach can be wrong for mass products. Methodics is dedicated for machines that are manufactured individually and to a specific customer order. The basic goals of applying modularity in this case are: shortening order processing time, cost reduction and quality improvement. Verification of technical solutions

should take place during the design process of individual elements.

REFERENCES

- [1] Huang Ch, Kusiak A., *Development of Modular Products*, IEEE Transactions on Components, Packaging and Manufacturing Technology – Part A, Vol. 19 No 4, Dec 1996
- [2] Huang Ch, Kusiak A, *Modularity in Design of Products and Systems*, IEEE Transactions on Systems, Man and Cybernetics – Part A, Vol. 28 No. 1, Jan 1998
- [3] Erixon G., *Design for Modularity*, in: Huang: Design for X, Chapman and Hall 1996
- [4] Iżykowski S. (red), *News and Trends in Development of Manufacturing Machines*, Scientific Papers of the Institute of Mechanical Engineering and Automation of the Wrocław University of Technology, Conference Automation in Manufacturing 2000, Wrocław 2000